

RONDA 515 – Essential Swiss Accuracy

The Ronda 515 embodies Swiss reliability. Offering hours, minutes, seconds, and date, it is admired for its long-term stability and durability a versatile calibre with uncompromising precision.



11 1/2^{'''}



512

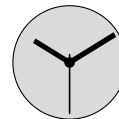

513

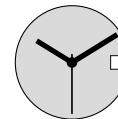

515

Funktionen

Fonctions

Functions

Kaliber	Stellwellenpos.	Funktionen
Calibre	Pos. de tige	Fonctions
Caliber	Stem position	Functions
512, 513	1	Normale Position / Position normale / Running position
	2	Zeiger stellen, Sekunden-Stopp mit Unterbruch der Motorimpulse Mise à l'heure, stop-seconde avec interruption des impulsions moteur Hand setting, stop-second with interruption of motor pulses
515	1	Normale Position / Position normale / Running position
	2	Datumskorrektur / Correction de la date / Date correction
	3	Zeiger stellen, Sekunden-Stopp mit Unterbruch der Motorimpulse Mise à l'heure, stop-seconde avec interruption des impulsions moteur Hand setting, stop-second with interruption of motor pulses

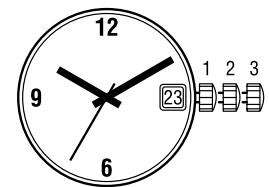

Batterie

Pile

Battery

Kaliber	Batterie	Spannung	Artikelnummer RONDA
Calibre	Pile	Voltage	Numero d'article RONDA
Caliber	Battery	Tension	Part number RONDA
512, 513, 515	371/SR920SW	1.55 V	3600.015.HGF

Werkaufbau

Assemblage

Assembling

11 1/2''' 512, 513, 515

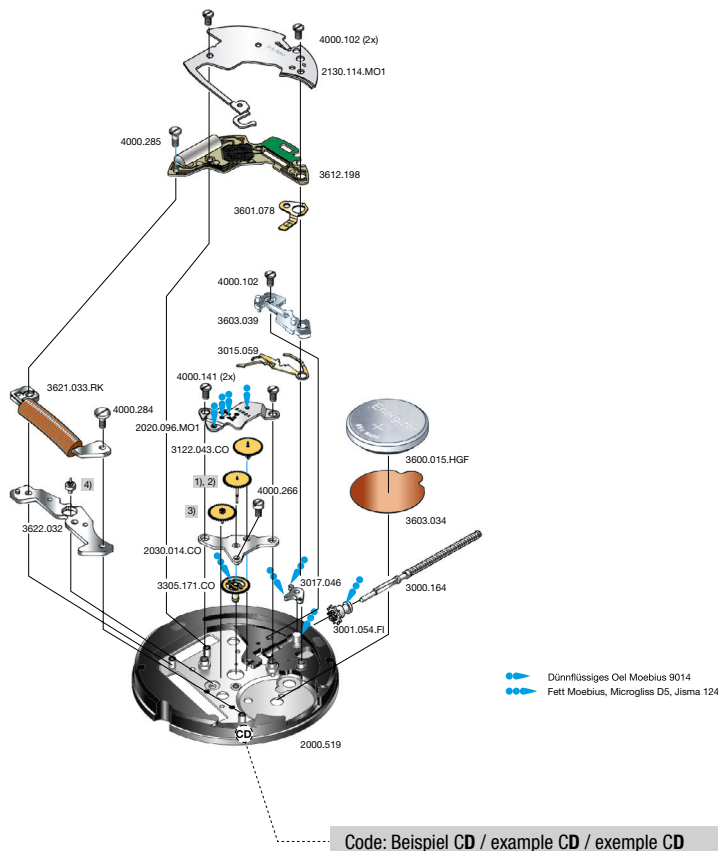

Cal. 513	Werkseite / Côté mouvement / Movement side		
Plan No.	Bestandteile	Fournitures	Spare Parts
2000.519	Werkplatte	Platine	Main plate
2020.096.MO1	Räderwerkbrücke	Pont rouage	Train w. bridge
2030.014.CO	Zentrumbrücke	Pont centre	Centre bridge
2130.114.MO1	Modul-Abdeckp.	Couvre module	Module cover pl.
3000.164	Stellwelle	Tige	Stem
3001.054.FI	Kupplungstrieb	Pignon coulant	Sliding pinion
3015.059	Kuppl.-triebhebel	Bascule	Yoke
3017.046	Winkelhebel	Tirette	Setting lever
3122.043.CO	Kleinbodenrad	Roue moyenne	Third wheel
1)	Sekundenrad	Roue secondes	Second-wheel
3)	Zwischenrad	Roue interméd.	Intermed. wheel
3305.171.CO	Minutenrohr	Chaussée	Cannon pinion
3600.015.HGF	Batterie	Pile	Battery
3601.078	Batterie-Kontakt	Bride contact	Battery contact
3603.034	Batterie-Isolation	Isolateur pile	Battery insulation
3603.039	Deckplatte/ Ste.	Couvre mécan.	Setting lev. cover
3612.198	Modul	Module	Module
3621.033.RK	Spule	Bobine	Coil
3622.032	Stator	Stator	Stator
4)	Rotor	Rotor	Rotor
4000.102	Schraube	Vis	Screw
4000.141	Schraube	Vis	Screw
4000.266	Schraube	Vis	Screw
4000.284	Schraube	Vis	Screw
4000.285	Schraube	Vis	Screw

Abweichungen / Divergences / Deviations

Cal. 515	Werkseite / Côté mouvement / Movement side		
Plan No.	Bestandteile	Fournitures	Spare Parts
3015.060	Kuppl.-triebhebel	Bascule	Yoke

Cal. 512	Werkseite / Côté mouvement / Movement side		
Plan No.	Bestandteile	Fournitures	Spare Parts
2030.012.CO	Zentrumbrücke	Pont centre	Centre bridge
2)	Sekundenrad	Roue secondes	Second-wheel
3)	Zwischenrad	Roue interméd.	Intermed. wheel
3305.210.CO	Minutenrohr	Chaussée	Cannon pinion
4)	Rotor	Rotor	Rotor

Cal. 513, 515		
	Bis Juni 2015 Jusqu' en Juin 2015 Untill June 2015	Ab Juli 2015 A partir de Juillet 2015 From July 2015
Code	2. Buchstabe ... C Second letter ... C 2 ^{ème} chiffre: ... C	2. Buchstabe: ab D Second letter: from D 2 ^{ème} chiffre: à partir de D

1)	3136.090.CO	3136.194.CO
3)	3147.019.CO	3147.092.CO
4)	3715.089.RK	3715.144.RK

Die obigen 3 Teile bilden jeweils eine Gruppe. Deshalb sind die 3 Teile jeder Gruppe nicht einzeln gegeneinander austauschbar.

Les 3 fournitures ci-dessous forment un groupe individuel. C'est pourquoi les 3 fournitures de chaque groupe ne sont pas interchangeables.

The 3 parts mentioned above are forming an individual group. Therefore the 3 parts of each group are not interchangeable.

Cal. 512		
	Bis Juni 2015 Jusqu' en Juin 2015 Untill June 2015	Ab Juli 2015 A partir de Juillet 2015 From July 2015
Code	2. Buchstabe ... C Second letter ... C 2 ^{ème} chiffre: ... C	2. Buchstabe: ab D Second letter: from D 2 ^{ème} chiffre: à partir de D

Die obigen 3 Teile bilden jeweils eine Gruppe. Deshalb sind die 3 Teile jeder Gruppe nicht einzeln gegeneinander austauschbar.

Les 3 fournitures ci-dessous forment un groupe individuel. C'est pourquoi les 3 fournitures de chaque groupe ne sont pas interchangeables.

The 3 parts mentioned above are forming an individual group. Therefore the 3 parts of each group are not interchangeable.

Werkaufbau

11 1/2''' 515

Assemblage

Assembling

11 1/2''' 512, 513

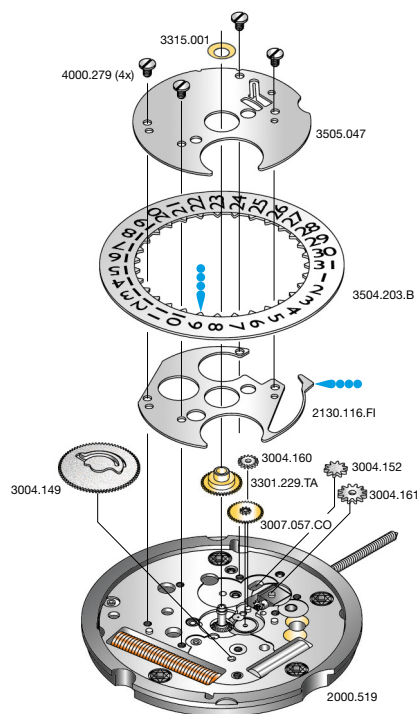

 Fett Moebius, Microglass I 4

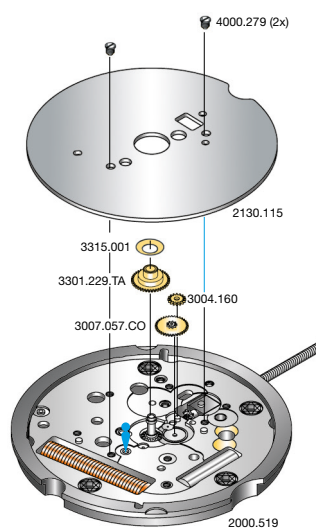

 Düninflüssiges Oel Moebius 9014

Cal. 515 Zifferblattseite / Côté cadran / Dial side			
Plan No.	Bestandteile	Fournitures	Spare Parts
2130.116.FI	Kalenderplatte	Plaque calendrier	Date ind. plate
3004.149	Datummitn.-rad	Renvoi entraîn.	Ind. driving wheel
3004.152	Umkehrad	Baladeur	Sliding gear
3004.160	Zeigerstellrad	Renvoi minuterie	Setting wheel
3004.161	Verbindungsrad-Kupplungtrieb	Renvoi pig. coulant	Sliding pinon setting wheel
3007.057.CO	Wechselrad	Minuterie	Minute wheel
3301.229.TA	Stundenrad	Canon	Hour wheel
3315.001	Spreizfeder	Clinquant	Washer
3504.203.B	Datumanzeiger	Bague	Date indicator
3505.047	Kal.-Abdeckplatte	Couvercle calend.	Date ind. cover
4000.279	Schraube	Vis	Screw

Cal. 512, 513 Zifferblattseite / Côté cadran / Dial side			
Plan No.	Bestandteile	Fournitures	Spare Parts
2130.115	Zeigerwerkplatte	Plaque maintien	Maintening plate
3004.160	Zeigerstellrad	Renvoi minuterie	Setting wheel
3007.057.CO	Wechselrad	Minuterie	Minute wheel
3301.229.TA	Stundenrad	Canon	Hour wheel
3315.001	Spreizfeder	Clinquant	Washer
4000.279	Schraube	Vis	Screw

Elektr. Messungen

Contrôles électriques

Electrical checking

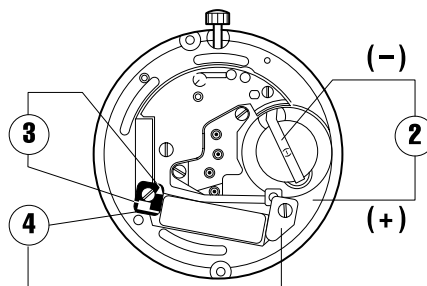
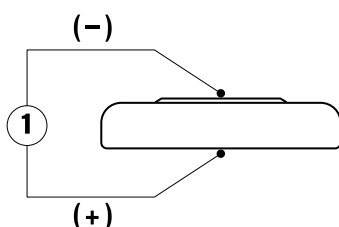

Kaliber Calibre Caliber	Pos. Pos. Pos.	Einheit Unité Unit	Messwerte Valeurs mesurées Measured values	Kontrolle Contrôle Check	Bemerkungen Remarques Remarks
512, 513, 515	1	V	1,55	Batterie-Spannung Tension de la pile Battery voltage	Batterie herausnehmen und messen Enlever et mesurer la pile Remove battery for measuring
512, 513, 515	2	µA	1,10–1,85 2,20–2,65	Stromaufnahme Consom. de courant Power consumption	Ohne Batterie, mit externer Speisung Sans pile, avec alimentation externe Without battery, with external power supply
512, 513, 515	2	V	≤ 1,30	Funktionskontrolle bei Minimalspannung Contrôle de fonctionnement à tension minimale Check with lowest possible voltage	Ohne Batterie, mit externer Speisung Sans pile, avec alimentation externe Without battery, with external power supply
512, 513, 515	3	K Ω	1,90–2,10 2,35–2,55	Spulenwiderstand Résistance de la bobine Resistance of the coil	Ohne Batterie Sans pile Without battery
512, 513, 515	4	K Ω	∞	Spulenisolation Isolation de la bobine Coil insulation	Ohne Batterie Sans pile Without battery
512, 513, 515		Sek./Monat sec./mois sec./month	- 10/+ 20	Induktivsonde 60 Sek. Senseur inductif 60 sec. Inductive sensor 60 sec.	Mit Batterie Avec pile With battery

Einschalen / Werkzeuge

Emboîtage / outils

Casing / tools

Nr. H 51x.1A



Nr. H 51x.1T



SWISS MADE & SWISS PARTS	
Schraube Vis Screw	

Zeigersetzen

Maximale Aufpresskraft:

- Stunden und Minutenzeiger: max. 40N
- Sekundenzeiger: max. 30N

Beim Zeigersetzen muss das Werk abgestützt werden.

Poser les aiguilles

Force de chassage maximale:

- Aiguilles des heure et des minutes: max. 40N
- Aiguille des secondes: max. 30N

Lors de la pose d'aiguilles, le mouvement doit être soutenu.

Hand setting

Maximal force:

- Hour and minute hands: max. 40N
- Second hand: max. 30N

The movement needs to be supported for hand setting.

Kal. 512, 513 Stellwelle entfernen	Kal. 515 Stellwelle entfernen
Beim Entfernen der Stellwelle muss sich die Stellwelle in Position 1 (gedrückt) befinden, bevor auf den Winkelhebel gedrückt wird.	Beim Entfernen der Stellwelle muss sich die Stellwelle in Position 2 befinden, bevor auf den Winkelhebel gedrückt wird.

Kal. 512, 513 Enlever la tige	Kal. 515 Enlever la tige
En enlevant la tige, la tige doit se trouver en position 1 (poussée), avant de pousser sur la tirette.	En enlevant la tige, la tige doit se trouver en position 2 , avant de pousser sur la tirette.

Kal. 512, 513 Stem removal	Kal. 515 Stem removal
For removal of the stem, the stem must be in position 1 (pressed in) prior to apply pressure to the setting lever.	For removal of the stem, the stem must be in position 2 prior to apply pressure to the setting lever.

Ronda 715 - Refined Swiss Precision

It is a three-hand Swiss Made movement designed for lasting accuracy and optimized energy consumption. Essential and refined, it brings discreet elegance to every moment.

User's Manual English Movements Caliber

RONDA powertech

- 585
- 505
- 515

RONDA slimtech

- 1005
- 1006
- 1009
- 1015
- 1016
- 1019

RONDA normtech

- 774 - 6003.D
- 775 - 6004.D
- 704 - 6003.B
- 705 - 6004.B
- 784
- 785
- 714
- 715
- 715Li

RONDA mastertech

- 7002.B
- 7003.B
- 7004.B

You have decided to buy a watch, which was assembled by a watchmaker using a Ronda movement. Please note that no watches are produced or distributed under the Ronda brand.

In case of repairs, guarantee claims and questions concerning the functioning of a watch, purchasers and consumers should contact their retailer or the watch manufacturer, for which the relevant information can be found in the sales or guarantee documentation provided with the watch.

Cal. 585	Cal. 6003.D
Cal. 505	Cal. 6004.D
Cal. 515	Cal. 6003.B
	Cal. 6004.B

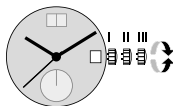

Pos. I Position of rest (watch running)

Pos. II Quick-change correction for date

The date can also be corrected during the day-changing phase between 10 pm and midnight. The date of the following day has to be set, because no automatic date change takes place at midnight.

- Pull the crown out to position II (watch still running).
- Turn the crown clockwise until the required date appears.
- Cal. 6003.D & 6004.D:
- Turn the crown until the required date appears.
- Push the crown back into position I.

Pos. III Setting the time

- Pull the crown out to position III (watch stopped).
- Turn the crown, until the current time is displayed (remember the 24-hour cycle).
- Push the crown back into position I.

Cal. 774	Cal. 715Li
Cal. 775	
Cal. 704	Cal. 1005
Cal. 705	Cal. 1006
Cal. 784	Cal. 1009
Cal. 785	Cal. 1015
Cal. 714	Cal. 1016
Cal. 715	Cal. 1019



Pos. I Position of rest (watch running)

Pos. II Quick-change correction for date

Blocking time for the quick-change day correction is from approx. 9.30 pm and midnight.

- Pull the crown out to position II (watch still running).
- Turn the crown until the current date appears.
- Push the crown back into position I.

Pos. III Setting the time

- Pull the crown out to position III (watch stopped).
- Turn the crown, until the current time is displayed (remember the 24-hour cycle).
- Push the crown back into position I.

Cal. 7002.B
Cal. 7003.B
Cal. 7004.B

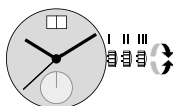

Pos. I Position of rest (watch running)

Pos. II Quick-change correction for date

The date can also be changed during the day-changing phase between approx. 8.00 pm and midnight. The date of the following day has to be set, because no automatic date change takes place at midnight.

- Pull the crown out to position II (watch still running).
- Turn the crown until the current date appears.
- Push the crown back into position I.

Pos. III Setting the time

- Pull the crown out to position III (watch stopped).
- Turn the crown, until the current time is displayed (remember the 24-hour cycle).
- Push the crown back into position I.

Ronda 785 - Uncompromising Swiss Precision

It is a Swiss Made quartz movement embodying the essence of Swiss precision. Elegant, efficient, and reliable, it delivers flawless timekeeping and an elevated experience of everyday performance.

User's Manual English Movements Caliber

RONDA powertech

- 585
- 505
- 515

RONDA slimtech

- 1005
- 1006
- 1009
- 1015
- 1016
- 1019

RONDA normtech

- 774 - 6003.D
- 775 - 6004.D
- 704 - 6003.B
- 705 - 6004.B
- 784
- 785
- 714
- 715
- 715Li

RONDA mastertech

- 7002.B
- 7003.B
- 7004.B

You have decided to buy a watch, which was assembled by a watchmaker using a Ronda movement. Please note that no watches are produced or distributed under the Ronda brand.

In case of repairs, guarantee claims and questions concerning the functioning of a watch, purchasers and consumers should contact their retailer or the watch manufacturer, for which the relevant information can be found in the sales or guarantee documentation provided with the watch.

Cal. 585	Cal. 6003.D
Cal. 505	Cal. 6004.D
Cal. 515	Cal. 6003.B
	Cal. 6004.B

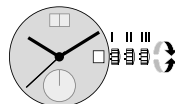

Pos. I Position of rest (watch running)

Pos. II Quick-change correction for date

The date can also be corrected during the day-changing phase between 10 pm and midnight. The date of the following day has to be set, because no automatic date change takes place at midnight.

- Pull the crown out to position II (watch still running).
- Turn the crown clockwise until the required date appears.
- Cal. 6003.D & 6004.D:
- Turn the crown until the required date appears.
- Push the crown back into position I.

Pos. III Setting the time

- Pull the crown out to position III (watch stopped).
- Turn the crown, until the current time is displayed (remember the 24-hour cycle).
- Push the crown back into position I.

Cal. 774	Cal. 715Li
Cal. 775	
Cal. 704	Cal. 1005
Cal. 705	Cal. 1006
Cal. 784	Cal. 1009
Cal. 785	Cal. 1015
Cal. 714	Cal. 1016
Cal. 715	Cal. 1019



Pos. I Position of rest (watch running)

Pos. II Quick-change correction for date

Blocking time for the quick-change day correction is from approx. 9.30 pm and midnight.

- Pull the crown out to position II (watch still running).
- Turn the crown until the current date appears.
- Push the crown back into position I.

Pos. III Setting the time

- Pull the crown out to position III (watch stopped).
- Turn the crown, until the current time is displayed (remember the 24-hour cycle).
- Push the crown back into position I.

Cal. 7002.B
Cal. 7003.B
Cal. 7004.B

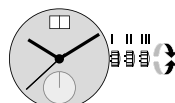

Pos. I Position of rest (watch running)

Pos. II Quick-change correction for date

The date can also be changed during the day-changing phase between approx. 8.00 pm and midnight. The date of the following day has to be set, because no automatic date change takes place at midnight.

- Pull the crown out to position II (watch still running).
- Turn the crown until the current date appears.
- Push the crown back into position I.

Pos. III Setting the time

- Pull the crown out to position III (watch stopped).
- Turn the crown, until the current time is displayed (remember the 24-hour cycle).
- Push the crown back into position I.

RONDA 1062 – Ultra-slim Elegance

The Ronda 1062 is an ultra-thin Swiss Made quartz calibre designed for sleek and elegant watch designs. Pure lines, discreet sophistication, and precision without compromise.



6 ³/₄ x 8'''



1062

Funktionen

Fonctions

Functions

Kaliber Calibre Caliber	Stellwellenpos. Pos. de tige Stem position	Funktionen Fonctions Functions
1062	1	Normale Position / Position normale / Running position
	2	Zeiger stellen, Stopp mit Unterbruch der Motorimpulse Mise à l'heure, stop avec interruption des impulsions moteur Hand setting, stop with interruption of motor pulses

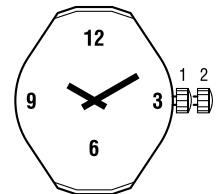

Batterie

Pile

Battery

Kaliber Calibre Caliber	Batterie Pile Battery	Spannung Voltage Tension	Artikelnummer RONDA Numero d'article RONDA Part number RONDA
1062	321 / SR616SW	1.55 V	3600.023.HGF

Werkaufbau

Assemblage

Assembling

6 3/4 x 8''' 1062

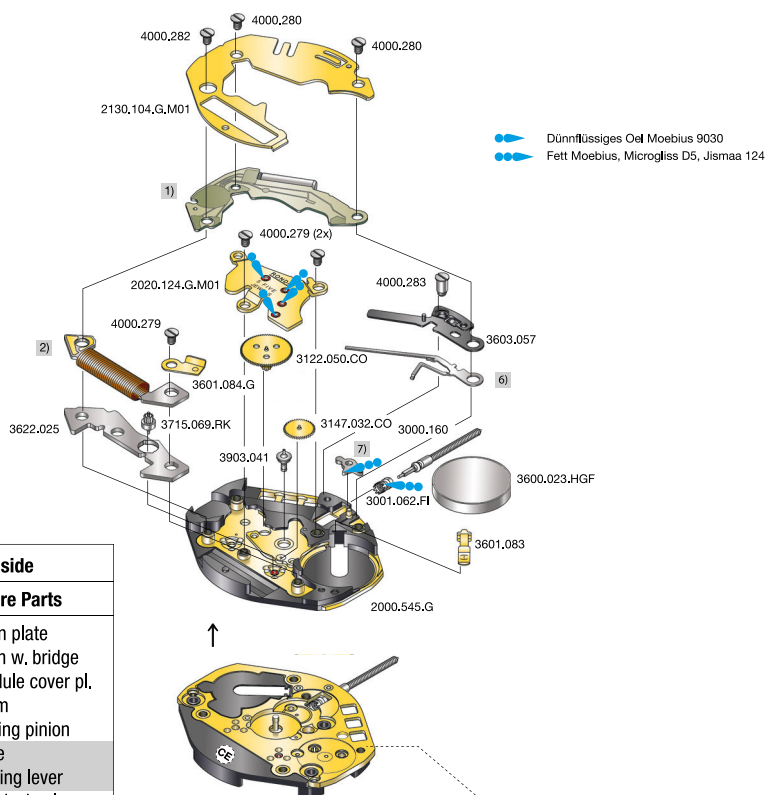

Code: Beispiel CE / exemple CE / exemple CE
(auf der Zifferblattseite / sur côté cadran / on dial side)

Cal. 1062	Werkseite / Côté mouvement / Movement side		
Plan No.	Bestandteile	Fournitures	Spare Parts
2000.545.G	Werkplatte	Platine	Main plate
2020.124.G.M01	Räderwerkbrücke	Pont rouge	Train w. bridge
2130.104.G.M01	Modul-Abdeckp.	Couvre module	Module cover pl.
3000.160	Stellwelle	Tige	Stem
3001.062.FI	Kupplungstrieb	Pignon coulant	Sliding pinion
6)	Kuppl.-triebhebel	Bascule	Yoke
7)	Winkelhebel	Tirette	Setting lever
3122.050.CO	Kleinbodenrad	Roue moyenne	Third wheel
3147.032.CO	Zwischenrad	Roue interméd.	Intermed. wheel
3600.023.HGF	Batterie	Pile	Battery
3601.083	Batt.-Kontakt (-)	Bride contact (-)	Batt. contact (-)
3601.084.G	Batteriehalter (+)	Bride de pile (+)	Battery clamp (+)
3603.057	Deckplatte/Ste.	Couvre mécan.	Setting lever cov.
1)	Modul	Module	Module
2)	Spule	Bobine	Coil
3622.025	Stator	Stator	Stator
3715.069.RK	Rotor	Rotor	Rotor
3903.041	Zentrumlagerrohr	Tube chaussée	Center tube
4000.279	Schraube	Vis	Screw
4000.280	Schraube	Vis	Screw
4000.282	Schraube	Vis	Screw
4000.283	Schraube	Vis	Screw

Code	Ab: 01 A partir de: 01 From: 01	Ab Januar 2017 A partir de Jan 2017 From January 2017
------	---------------------------------------	---

1062 SWISS MADE & SWISS PARTS		
6)	Kuppl. Triebhebel Bascule Yoke	3015.103
7)	Winkelhebel Tirette Setting lever	3017.068

Code	2. Buchstabe ... F 2 ^{ème} chiffre ... F Second letter ... F	Bis Dezember 2016 Jusqu' en Décembre 2016 Until December 2016
------	---	---

1062 SWISS MADE & SWISS PARTS		
6)	Kuppl. Triebhebel Bascule Yoke	3015.052
7)	Winkelhebel Tirette Setting lever	3017.043

Die obigen 2 Teile bilden jeweils ein Paar. Deshalb sind die 2 Teile jeder Gruppe nicht einzeln gegeneinander austauschbar.

Les 2 fournitures ci-dessous forment une pair. C'est pourquoi les 2 fournitures de chaque groupe ne sont pas interchangeables.

The 2 parts mentioned above are forming a pair. Therefore the 2 parts of each group are not interchangeable.

Code	2. Buchstabe: ab F 2 ^{ème} chiffre: à partir de F Second letter: from F	Ab Juli 2016 A partir de Juillet 2016 From July 2016
------	--	--

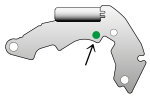
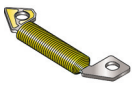
1062 SWISS MADE & SWISS PARTS		
1)	Modul (neu) Module (nouvelle) Module (new)	3612.264 grün vert green 
2)	Spule (neu) Bobine (nouvelle) Coil (new)	3621.084.RK gelb jaune yellow 

Code	2. Buchstabe ... E 2 ^{ème} chiffre ... E Second letter ... E	Bis Juni 2016 Jusqu' en Juin 2016 Until June 2016
------	---	---

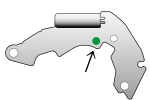
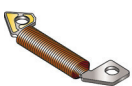
1062 SWISS MADE & SWISS PARTS		
1)	Modul (alt) Module (vielle) Module (old)	3612.204 grün vert green 
2)	Spule (alt) Bobine (vielle) Coil (old)	3621.027.RK rot rouge red 

Die obigen 2 Teile bilden jeweils ein Paar. Deshalb sind die 2 Teile jeder Gruppe nicht einzeln gegeneinander austauschbar.

Les 2 fournitures ci-dessous forment une pair. C'est pourquoi les 2 fournitures de chaque groupe ne sont pas interchangeables.

The 2 parts mentioned above are forming a pair. Therefore the 2 parts of each group are not interchangeable.



Werkaufbau

Assemblage

Assembling

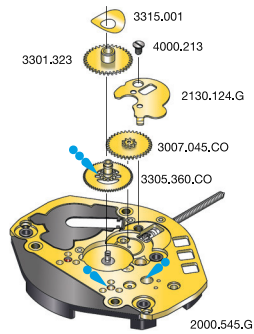
6 3/4 x 8''' 1062



 Düninflüssiges Öl Moebius 9030
 Fett Moebius, Microgliss D5, Jismaa 124

Cal. 1062 Zifferblattseite / Côté cadran / Dial side			
Plan No.	Bestandteile	Fournitures	Spare Parts
2130.124.G	Zeigerwerkplatte	Plaque maintien	Maintaining plate
3007.045.CO	Wechselrad	Minuterie	Minute wheel
3301.323	Stundenrad	Canon	Hour wheel
3305.360.CO	Minutenrohr	Chaussée	Cannon pinion
3315.001	Spreizfeder 2 1/2	Clinquant 2 1/2	Washer 2 1/2
4000.213	Schraube	Vis	Screw

Elektr. Messungen

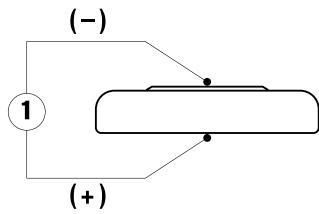

Contrôles électriques

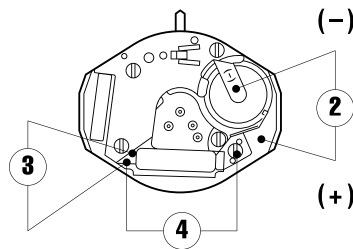

Electrical checking

Kaliber Calibre Caliber	Pos. Pos. Pos.	Einheit Unité Unit	Messwerte Valeurs mesurées Measured values	Kontrolle Contrôle Check	Bemerkungen Remarques Remarks
1062	1	V	1,55	Batterie-Spannung Tension de la pile Battery voltage	Batterie herausnehmen und messen Enlever et mesurer la pile Remove battery for measuring
1062* by pulses	2	µA	0,20–0,40 < 2,40	Stromaufnahme* (Puls Periode 10 Sekunden) Consom. de courant* (impulsion 10 secondes) Power consumption* (pulse period 10 seconds)	Ohne Batterie, mit externer Speisung Sans pile, avec alimentation externe Without battery, with external power supply
1062	2	V	< 1,30	Funktionskontrolle bei Minimalspannung Contrôle de fonctionnement à tension minimale Check with lowest possible voltage	Ohne Batterie, mit externer Speisung Sans pile, avec alimentation externe Without battery, with external power supply
1062	3	KΩ	* 1,39–1,45 ** 2,70–2,90	Spulenwiderstand Résistance de la bobine Resistance of the coil	Ohne Batterie Sans pile Without battery
1062	4	KΩ	∞	Spulenisolation Isolation de la bobine Coil insulation	Ohne Batterie Sans pile Without battery
1062		Sek./Monat sec./mois sec./month	- 10/+ 20	Induktivsonde 60 Sek. Senseur inductif 60 sec. Inductive sensor 60 sec.	Mit Batterie Avec pile With battery

* Code auf Werkplatte, 2. Buchstabe: ab F
Code sur platine, 2^{ème} chiffre: à partir de F
Code on main plate, second letter: from F

Ab Juli 2016
A partir de Juillet 2016
From July 2016

** Code auf Werkplatte, 2. Buchstabe ... E
Code sur platine, 2^{ème} chiffre ... E
Code on main plate, second letter ... E

Bis Juni 2016
Jusqu' en Juin 2016
Until June 2016

Einschalen / Werkzeuge





Nr. H 106X.1A



Emboîtage / outils

Nr. H 106X.1T



	SWISS MADE ⊕ 6h		SWISS PARTS ⊕ 6h	
1062	–	–	–	–
1063		–		–
1064	–		–	
1069	–	–	–	–

Zeigersetzen

Maximale Aufpresskraft:

- Stunden und Minutenzeiger: max. 40N
- Sekundenzeiger: max. 30N

Beim Zeigersetzen muss das Werk abgestützt werden.

Poser les aiguilles

Force de chassage maximale:

- Aiguilles des heure et des minutes: max. 40N
- Aiguille des secondes: max. 30N

Lors de la pose d'aiguilles, le mouvement doit être soutenu.

Hand setting

Maximal force:

- Hour and minute hands: max. 40N
- Second hand: max. 30N

The movement needs to be supported for hand setting.

Stellwelle entfernen

Beim Entfernen der Stellwelle muss sich die Stellwelle in Position 1 (gedrückt) befinden, bevor auf den Winkelhebel gedrückt wird.

Enlever la tige

En enlevant la tige, la tige doit se trouver en position 1 (poussée), avant de pousser sur la tirette.

Stem removal

For removal of the stem, the stem must be pushed into position 1 (pressed in) prior to apply pressure to the setting lever.

Ronda 704 - Swiss Elegance and Precision

It is a Swiss Made quartz calibre that blends refined aesthetics with technical excellence. With clean lines and essential functions, it offers the perfect balance between elegance and high performance.

User's Manual English Movements Caliber

RONDA powertech

- 585
- 505
- 515

RONDA slimtech

- 1005
- 1006
- 1009
- 1015
- 1016
- 1019

RONDA normtech

- 774 - 6003.D
- 775 - 6004.D
- 704 - 6003.B
- 705 - 6004.B
- 784
- 785
- 714
- 715
- 715Li

RONDA mastertech

- 7002.B
- 7003.B
- 7004.B

You have decided to buy a watch, which was assembled by a watchmaker using a Ronda movement. Please note that no watches are produced or distributed under the Ronda brand.

In case of repairs, guarantee claims and questions concerning the functioning of a watch, purchasers and consumers should contact their retailer or the watch manufacturer, for which the relevant information can be found in the sales or guarantee documentation provided with the watch.

Cal. 585	Cal. 6003.D
Cal. 505	Cal. 6004.D
Cal. 515	Cal. 6003.B
	Cal. 6004.B

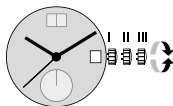

Pos. I Position of rest (watch running)

Pos. II Quick-change correction for date

The date can also be corrected during the day-changing phase between 10 pm and midnight. The date of the following day has to be set, because no automatic date change takes place at midnight.

- Pull the crown out to position II (watch still running).
- Turn the crown clockwise until the required date appears.
- Cal. 6003.D & 6004.D:
- Turn the crown until the required date appears.
- Push the crown back into position I.

Pos. III Setting the time

- Pull the crown out to position III (watch stopped).
- Turn the crown, until the current time is displayed (remember the 24-hour cycle).
- Push the crown back into position I.

Cal. 774	Cal. 715Li
Cal. 775	
Cal. 704	Cal. 1005
Cal. 705	Cal. 1006
Cal. 784	Cal. 1009
Cal. 785	Cal. 1015
Cal. 714	Cal. 1016
Cal. 715	Cal. 1019



Pos. I Position of rest (watch running)

Pos. II Quick-change correction for date

Blocking time for the quick-change day correction is from approx. 9.30 pm and midnight.

- Pull the crown out to position II (watch still running).
- Turn the crown until the current date appears.
- Push the crown back into position I.

Pos. III Setting the time

- Pull the crown out to position III (watch stopped).
- Turn the crown, until the current time is displayed (remember the 24-hour cycle).
- Push the crown back into position I.

Cal. 7002.B
Cal. 7003.B
Cal. 7004.B

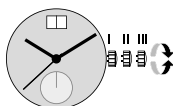

Pos. I Position of rest (watch running)

Pos. II Quick-change correction for date

The date can also be changed during the day-changing phase between approx. 8.00 pm and midnight. The date of the following day has to be set, because no automatic date change takes place at midnight.

- Pull the crown out to position II (watch still running).
- Turn the crown until the current date appears.
- Push the crown back into position I.

Pos. III Setting the time

- Pull the crown out to position III (watch stopped).
- Turn the crown, until the current time is displayed (remember the 24-hour cycle).
- Push the crown back into position I.